

Code of Practice for Buses



July 2016

Central Inspection Authority



Government of South Australia
Department for Infrastructure
and Transport

Build.
Move.
Connect.

CONTENTS

1.	DEFINITIONS	4
2.	INTRODUCTION	5
3.	GENERAL REQUIREMENTS	6
3.1.	ADHERENCE TO THE CODE	6
3.2.	GROUND CLEARANCE	6
3.3.	LOCATION OF SUSPENSION LOAD CONTROLS	6
3.4.	ABILITY TO REVERSE	6
3.5.	ADDITIONAL REQUIREMENTS FOR DOUBLE-DECK BUSES	6
4.	MODIFICATION	7
4.1.	HEAVY BUS MODIFICATION	7
4.2.	LIGHT BUS MODIFICATION	7
4.3.	MODIFICATION CONDITIONS	7
5.	ACCESS	8
5.1.	ACCESS STEPS	8
5.2.	ACCESS DOORS	8
5.3.	AISLES	10
5.4.	HEAD ROOM	10
5.5.	EMERGENCY EXITS	11
6.	INTERIOR APPOINTMENTS	12
6.1.	GENERAL REQUIREMENTS	12
6.2.	HAND STRAPS AND RAILS	12
6.3.	INTERNAL GUARD RAILS AND PARTITION	12
6.4.	INTERIOR LUGGAGE RACKS	13
6.5.	FLOORS	13
6.6.	INTERIOR DOORS	13
6.7.	VENTILATION	13
6.8.	LAVATORIES AND WASH BASINS	13
6.9.	PASSENGER STOP SIGNAL	13
6.10.	SLEEPER BERTH	13
7.	SEATS	14
7.1.	DRIVER'S SEAT	14
7.2.	SEATS FOR PASSENGERS	14
7.3.	SEAT BELTS	15
8.	FIRE PROTECTION	16
8.1.	GENERAL REQUIREMENTS	16
8.2.	FUEL SYSTEMS	16
8.3.	FIRE EXTINGUISHERS	16
9.	LIGHTING	17
9.1.	SWITCHING	17
9.2.	INTERIOR LIGHTING	17
9.3.	REVERSING LIGHTS	17
9.4.	SPECIAL LIGHTING FOR ARTICULATED BUSES	17

10.	WHEELS AND TYRES.....	17
10.1.	CONDITION AND FITTING.....	17
10.2.	RIMS	18
11.	GLAZING	18
11.1.	WINDSCREENS	18
11.2.	WINDSCREEN WIPERS AND WASHERS.....	18
11.3.	DEMISTERS	18
11.4.	SURFACE FILM.....	18
12.	BRAKING	19
12.1.	OPERATION.....	19
12.2.	OPERATION OF ACCESSORIES	19
13.	EXHAUST	19
13.1.	EXHAUST SYSTEM.....	19
14.	OTHER EQUIPMENT	19
14.1.	STEERING	19
14.2.	DANGEROUS FITTINGS.....	19
14.3.	BULL BARS	19
14.4.	MUDGUARDS	19
14.5.	TAIL SHAFT GUARDS	19
14.6.	SPEEDOMETER.....	20
14.7.	VISIBILITY OF INSTRUMENTS AND WARNING DEVICES.....	20
15.	MAINTENANCE PROCEDURES	20
15.1.	ROADWORTHINESS.....	20
15.2.	SCHEME OF MAINTENANCE	20
15.3.	INSPECTION SHEET NO. 1	21
15.4.	INSPECTION SHEET NO. 2	21
15.5.	INSPECTION SHEET NO. 3	21
15.6.	MAINTENANCE RECORD	21
16.	INSPECTIONS	22
16.1.	GENERAL.....	22
16.2.	CERTIFICATE OF INSPECTIONS.....	22
16.3.	INSPECTION GUIDELINES	22
APPENDIX.....		23
A	RELATED THIRD EDITION ADRs.....	23
FIRST SCHEDULE: PART 1		24
FIRST SCHEDULE: PART 2		25
FIRST SCHEDULE: PART 4		27

1. DEFINITIONS

In this Code of Practice, unless the context otherwise requires, or some other meaning is clearly indicated:

“the Act” means the Road Traffic Act 1961, and any amendment to the Act.

“the Code” means the Code of Practice for Buses stipulated by the Central Inspection Authority, as amended, varied or substituted from time to time.

“maximum laden mass” means the maximum mass of a bus and its load borne on the surface on which it is standing or running.

“gross vehicle mass” means the *maximum laden mass*, specified by the manufacturer.

“bus” means a motor vehicle built mainly to carry people that seats over 12 adults (including the driver).

“large bus” means a bus with a seating capacity of more than 25 adult persons, including the driver, and may include a double-deck bus.

“small bus” means a bus with a seating capacity for not more than 25 adult persons, including the driver.

“heavy bus” means a bus with a *gross vehicle mass* exceeding 4.5 tonnes.

“light bus” means a bus with a *gross vehicle mass* not exceeding 4.5 tonnes.

“articulated bus” means a bus consisting of two or more rigid sections with access between the sections for passengers, and with the rear section connected to the front section so as to allow rotary movement between the sections.

“child” means a person up to and including the age of fourteen.

Note: in the Heavy Vehicle National Law and Regulation, “child” means a person up to and including the age of twelve.

2. INTRODUCTION

The Code of Practice for Buses has been developed to ensure uniformity in the standard of safety of buses, manufactured prior to 1 July 1988 and operating in South Australia.

Contained within are requirements, not directly covered by the Road Traffic Act and Regulations, relating in particular to the equipment and conditions of the passenger compartment in buses.

Buses manufactured after the introduction of the Third Edition Australian Design Rules, 1 July 1988, are required to meet the technical requirements of the ADRs rather than those stipulated in *the Code*.

Heavy buses manufactured after the introduction of the Australian Design Rules are required to meet the Heavy Vehicle National Law and Regulation rather than those stipulated in *the Code*.

Where applicable, the requirement of the Australian Design Rules or the Heavy Vehicle National Law and Regulation can be applied to *light* or *heavy buses* manufactured prior to 1 July 1988 respectively.

All buses, regardless of date of manufacture, are required to comply with Section 6.10 **Sleeper Berth**, where fitted, Section 7.3 **Seat Belts**, Section 10 **Wheels and Tyres**, and Section 15 **Maintenance Procedures** of *the Code*.

The Code has been stipulated by the Central Inspection Authority and will be used, together with the relevant requirements contained within the Road Traffic Act and Regulations, in deciding whether to issue or decline to issue a Certificate of Inspection in respect to a bus. It is essential for all persons in the bus industry to be familiar with the contents of *the Code*.

The Central Inspection Authority may vary or revoke an exemption granted to a person or company to use the Inspection Sheets described in *the Code*.

3. GENERAL REQUIREMENTS

3.1. Adherence to the Code

- 3.1.1 Every bus registered in South Australia shall comply with the requirements of *the Code*.
- 3.1.2 Buses manufactured to comply with Australian Design Rules shall meet the requirements of the Australian Design Rules relevant to the vehicle category and date of manufacture.

Note: Buses imported into Australia and not fitted with an Australian Design Rule Compliance Plate are required to meet the requirements of the Australian Design Rules for the month and year of manufacture of the chassis and or body whichever is the later date of manufacture.

3.2. Ground Clearance

- 3.2.1 The distance between a horizontal road surface and any point on the underside of the bus, except the tyres, wheels and wheel hubs, at all loading conditions shall be not less than 100 mm.

3.3. Location of Suspension Load Controls

- 3.3.1 Any device for controlling the loading of the axles of a bus should not be located within the interior of the bus, if such bus is first registered on or after 1 January 1978.

3.4. Ability to Reverse

- 3.4.1 Every bus shall be capable of being moved backwards and forwards under its own power.

3.5. Additional Requirements for Double-Deck Buses

- 3.5.1 Every double-deck bus shall comply with the following requirements.
- 3.5.2 The height of the floor of the upper deck shall not exceed 2,750 mm from the ground and shall be so constructed and drained as to prevent water entering the lower deck.
- 3.5.3 The upper deck shall be enclosed on all sides; and
- 3.5.4 The double-deck bus shall be stable when positioned on a 53.2% gradient, flat surface incline with a full load of passengers in the upper deck only.

4. MODIFICATION

4.1. Heavy Bus Modification

4.1.1 Alterations made to a *heavy bus* that affect its original specifications in any of the respects listed Section 4 **Modification Conditions**, shall comply with the Heavy Vehicle National Law and Regulation, where all work is certified by a Recognised Engineering Signatory as complying with [Vehicle Standards Bulletin No. 6](#) (VSB 6) Heavy Vehicle Modifications.

4.2. Light Bus Modification

4.2.1 Alterations made to a *light bus* that affect its original specification in any of the respects listed in Section 4 **Modification Conditions**, shall comply with the *Road Traffic (Light Vehicle Standards) Rules 2013*.

4.3. Modification Conditions

4.3.1 Fitting of an engine, air cleaner or exhaust with non-original manufacturer specification at the time of its manufacture.

4.3.2 Fitting of a turbocharger or road speed limiter.

4.3.3 Alteration of the transmission.

4.3.4 Alteration of the fuel system.

4.3.5 Alteration of the steering components from those provided in the vehicle or available as options for the vehicle from the original manufacturer of the bus at the time of manufacture.

4.3.6 Alteration of the steering geometry from that designed for the vehicle by the original manufacturer of the bus.

4.3.7 Alteration of the primary or auxiliary braking system.

4.3.8 Alteration of the wheelbase.

4.3.9 Alteration of the number of axles.

4.3.10 Alteration of the suspension system.

4.3.11 Alteration of the tail shaft.

4.3.12 Alteration of the chassis frame.

4.3.13 Fitting of a wheelchair loader.

4.3.14 Alteration of the seating capacity.

4.3.15 Fitting of seat belts or a wheelchair occupant restraint system.

4.3.16 Fitting of non-standard or non-original wheel rim and tyre; or

4.3.17 Alteration of wheel fitment, such as non-original wheel spacers or wheel nuts.

5. ACCESS

5.1. Access Steps

- 5.1.1 All access steps provided shall be fitted and maintained with a skid resistant tread.
- 5.1.2 The height of access steps shall be not more than 410 mm or less than 250 mm relative to the ground in the case of the lower step; and not more than 300 mm in the case of all other steps (Figure 1).
- 5.1.3 The depth of the tread surface of access steps shall not be less than 225 mm in the case of a large bus; or 180 mm in the case of a *small bus* (Figure 2).
- 5.1.4 The width of the access steps shall be not less than the width of the access opening in the case of the lower access step; the width of the aisle for the upper step; and 450 mm in the case of all other access steps (Figure 2).
- 5.1.5 Where more than one access step is provided the tread surface of one step may undercut the tread of the next highest step provided that when viewed from above not less than 180 mm of the lower step is visible, or 140 mm in the case of a *small bus*.
- 5.1.6 The stairway between decks of a double deck bus shall not be less than 400 mm in width. Such stairway shall be equipped with a guard rail and guard panel (Figure 3).

5.2. Access Doors

- 5.2.1 A bus with a longitudinal aisle shall have at least one access door for passengers on the left-hand side of the bus. Such access shall have a suitable handgrip affixed to each side, be not less than 500 millimetres wide and be clear of any obstruction.
- 5.2.2 The height of the access from the lowest step to the top of the opening shall be at least 1,800 mm in the case of a *large bus*; or at least 1,200 mm in the case of a *small bus* (Figure 1).
- 5.2.3 A bus without a longitudinal aisle and fitted with seats in transverse rows shall have a means of entrance and exit to each such row by a door fitted to the left-hand side of the bus. Any such means of entrance and exit shall not be less than 550 mm in width when measured at the height of the seat cushion and shall not be less than 1,375 mm in height from the floor level to the top of the door of such entrance and exit in the case of a *large bus* or 1,200 mm in the case of a *small bus*.
- 5.2.4 Except in the case of emergency exits means of access shall not be provided on the right-hand side of any bus other than to provide access to the drivers seating position.
- 5.2.5 All buses shall be provided with a door at every point of access. Every such door on a *large bus* involved in frequent stops for the purpose of taking up or setting down passengers shall be capable of being opened or unlocked and closed or locked by the driver when seated in the normal driving position.
- 5.2.6 Access doors shall not be designed to open inwards except in the case of any door commonly known as a “glide way” or “jack-knife” door provided that such a door is so constructed that it cannot protrude into the bus further than the steps provided at the access.
- 5.2.7 No access door shall be provided with an internal fitting designed to cover internal steps when such door is closed.

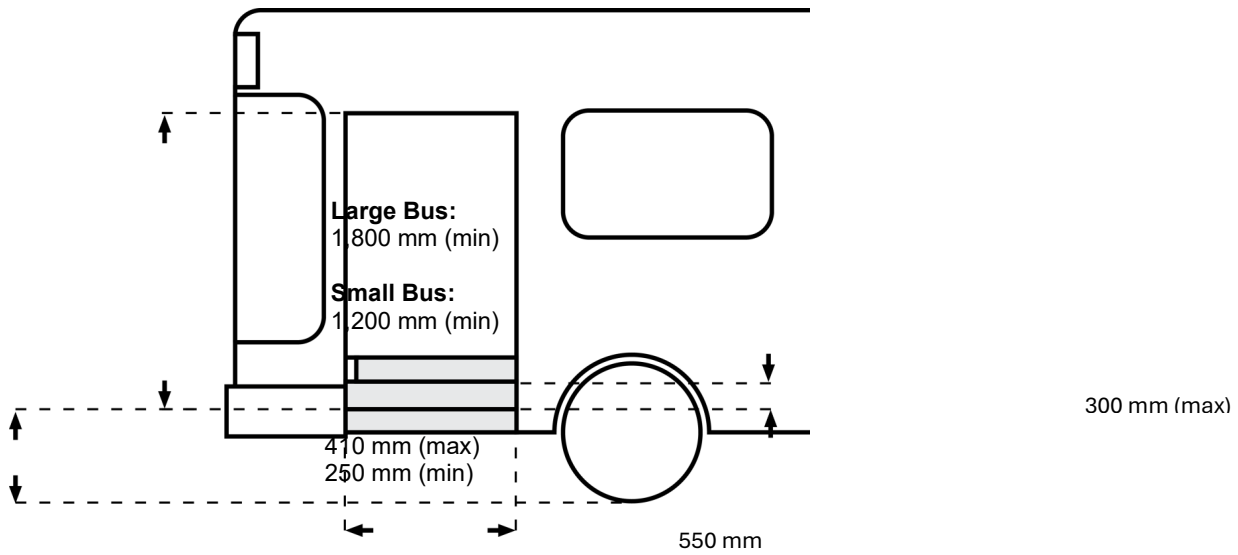

Figure 1: Side view of front access steps and door

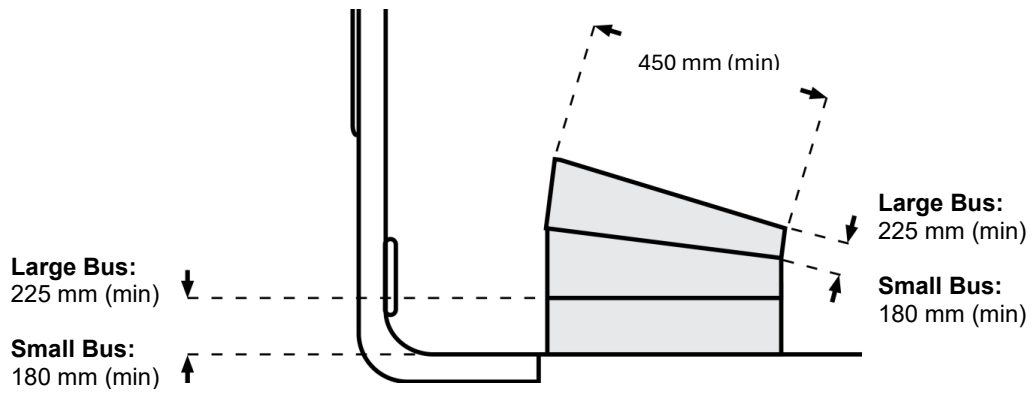

Figure 2: Top view of front access steps and door

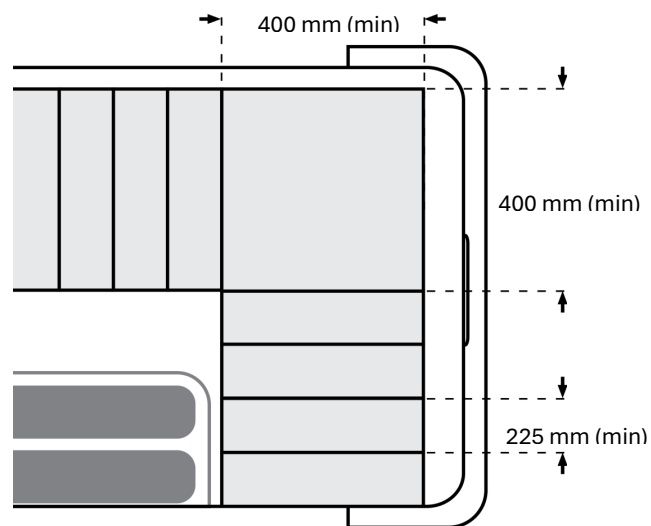

Figure 3: Top view of rear access steps for a double deck bus

5.3. Aisles

- 5.3.1 A single deck bus may be provided with a longitudinal aisle providing access to one or more rows of seats, providing that the width of such aisle is not less than 380 mm in the case of a *large bus* when passengers are allowed to stand while travelling; or 300 mm in the case of any other bus (Figure 4).
- 5.3.2 Double-deck buses other than those used for the carriage of seated passengers only shall be provided with a longitudinal aisle at each deck. The width of such aisles shall be not less than 380 mm. The width of the aisle of double-deck buses used only for the carriage of seated passengers shall be not less than 300 mm.
- 5.3.3 No part of the floor area of any longitudinal aisle shall have a gradient greater than 8% in areas intended for standing passengers or more than 12.5% for areas not intended for standing passengers.
- 5.3.4 Any aisle provided in a bus shall be clear of obstruction.

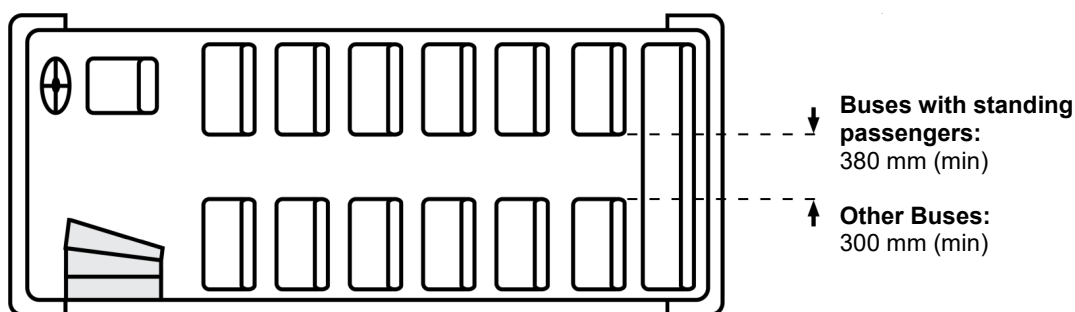

Figure 4: Top view of a bus

5.4. Head Room

- 5.4.1 In the case where access to seats in a bus is by a longitudinal aisle, the height inside the bus from any point on the longitudinal centre line of such aisle to the ceiling shall be not less than.
- 5.4.2 1,800 mm for *large buses* involved in frequent stops for the purpose of picking up or setting down passengers (Figure 5 right).
- 5.4.3 1,650 mm for each deck of a double deck bus and for *large buses* not involved in frequent stops for the purpose of taking up or setting down passengers (Figure 6).
- 5.4.4 1,350 mm for *small buses* where the aisle length is more than 2,000 mm (Figure 5 right); or
- 5.4.5 1,200 mm for *small buses* where the aisle length is not more than 2,000 mm (Figure 5 right).
- 5.4.6 In the case where access to a single row of seats in a bus is not by a longitudinal aisle the height inside the bus from any point on the longitudinal centre line of the bus to the ceiling shall not be less than 1,500 mm for a *large bus*; or 1,200 mm for a *small bus* (Figure 5 left).
- 5.4.7 The height inside a bus from any point on the access steps to the ceiling immediately above such point shall not be less than the appropriate minimum height specified in clause 5.4.1 and 5.4.2.

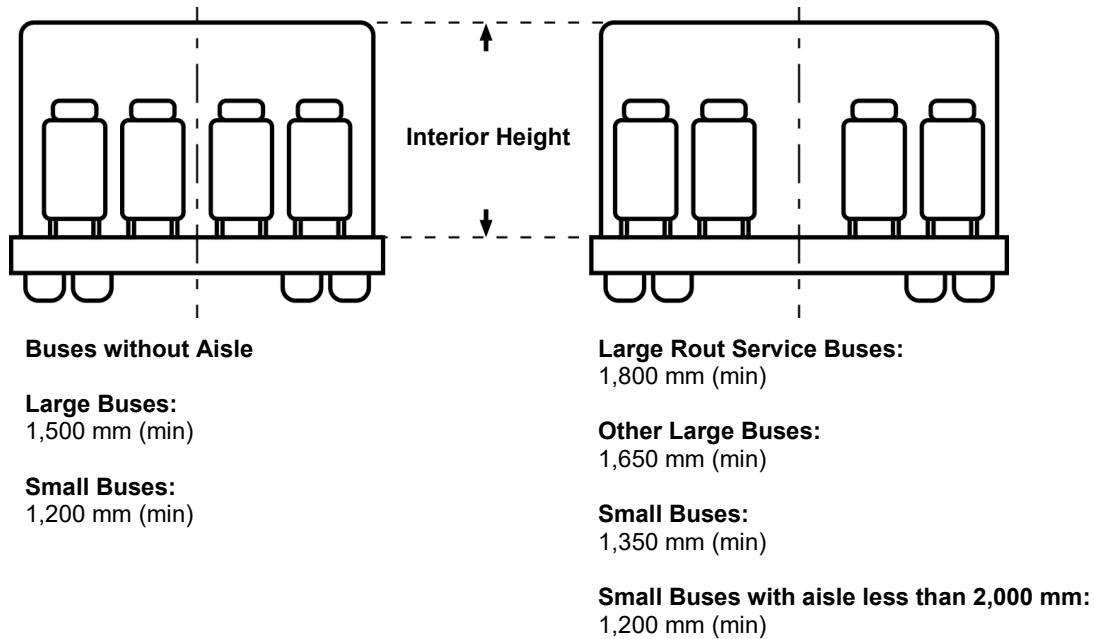

Figure 5: Section view of buses without (left) and with (right) aisle

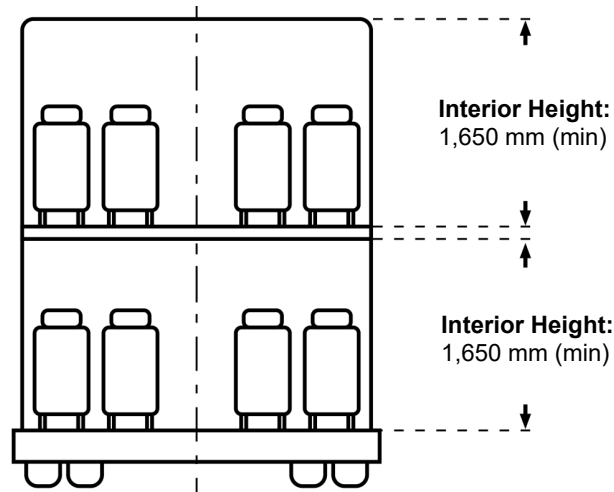

Figure 6: Section view of a double deck bus

5.5. Emergency Exits

- 5.5.1 A large single deck bus shall have means of emergency exit located.
- 5.5.2 In the extreme rear of the bus providing a minimum area of 0.7 m² clear of obstruction; or
- 5.5.3 In the roof of the rear half of the bus providing a minimum area of 0.7 m² clear of obstruction; and in the right-hand side of the rear half of the bus providing a minimum area of 0.32 m² clear of obstruction; or
- 5.5.4 In the roof of the bus providing two minimum areas clear of obstruction each of which are 0.4 m² with one such area being in the rear half of the bus; and in the right-hand side of the rear half of the bus providing a minimum area of 0.4 m² clear of obstruction.
- 5.5.5 A small single deck bus shall have a means of emergency exit located.
- 5.5.6 In the extreme rear of the bus providing a minimum area of 0.52 m² clear of obstruction; or
- 5.5.7 In the roof of the rear half of the bus providing a minimum area of 0.4 m² clear of obstruction; and in the right-hand side of the rear half of the bus providing a minimum area of 0.32 m² clear of obstruction.

- 5.5.8 A small single deck bus which is equipped to seat not more than 12 persons; does not exceed 2,000 mm in overall width; is fitted with one or more doors on each side of the bus; and provides access from every seating position to any door having an area not less than 0.7 m² with no dimension less than 500 mm; need not comply with the provision of Clause 5.5.2.
- 5.5.9 There shall not be any dimension of any emergency exit that is less than 500 mm.
- 5.5.10 In the case of a double deck bus there shall be in the rear on both levels an emergency exit that provides for a minimum area of 0.7 m² clear of obstruction per exit.
- 5.5.11 Emergency exits shall be capable of being opened outwards from both inside and outside the bus.
- 5.5.12 Emergency exits may be closed by the use of transparent plastic material, sheet metal or toughened glass carried in extruded rubber weather strips. The force required to remove the closing material when applied either internally or externally adjacent to any corner of such material shall be not more than 700 N nor less than 445 N.
- Note: sliding windows may be used as emergency exits provided all minimum dimensions are attained; and the force required to open the exit is within the limits specified in this clause.*
- 5.5.13 Every emergency exit shall be identified by a prominent notice inside and outside the bus displaying the words **EMERGENCY EXIT**. Words and or symbols shall indicate the method of opening unless by virtue of design the method opening is obvious.
- 5.5.14 Where visibility of an emergency exit sign required by this clause is restricted by a sleeper cab screen or curtain, or other means, an additional sign indicating the location of the emergency exit shall be located immediately forward of the restriction. This may be placed on the obstruction itself, e.g. on a curtain.
- 5.5.15 The height of the lower edge of the emergency exit, other than roof exits, relative to the floor immediately below it shall be not more than 1,000 mm nor less than 500 mm.
- 5.5.16 Devices for disabled access, e.g. wheelchair lift, fitted on a bus shall not block emergency exits.

6. INTERIOR APPOINTMENTS

6.1. General Requirements

- 6.1.1 Roof linings and other interior trimmings shall be of a material not readily flammable and if of absorbent material be treated to prevent absorption of liquids.
- 6.1.2 Hazardous projections, sharp corners and edges shall be eliminated to minimise the risk of injury to occupants.

6.2. Hand Straps and Rails

- 6.2.1 All buses shall be provided with a suitable number of hand straps, handrails or hand grips for the convenience and safety of passengers.

6.3. Internal Guard Rails and Partition

- 6.3.1 A guard rail or partition shall be provided to prevent persons from accidentally coming into contact with the driver or control devices of the bus; and prevent persons from falling into the step well from any seat located directly behind a step.

6.4. Interior Luggage Racks

- 6.4.1 Where luggage racks are provided they shall be affixed so that the vertical distance between the rack and the surface of the seat cushion, measured at the centre of the seat cushion, is not less than 950 mm.
- 6.4.2 Such luggage racks shall be so constructed as to minimise the possibility of injury to passengers from any projection or by dislodgement of any luggage during braking or cornering manoeuvres.

6.5. Floors

- 6.5.1 Floors shall be of sound construction, finished and maintained with a skid resistant surface, and sealed so as to prevent fumes from the engine and dust from the roadway from entering the interior of the bus.

6.6. Interior Doors

- 6.6.1 The passenger space shall not be separated from any emergency exits or access doors.

6.7. Ventilation

- 6.7.1 An effective means of ventilation shall be provided other than by means of windows and door openings.

6.8. Lavatories and Wash Basins

- 6.8.1 Any bus which is equipped with any closet, urinal, hand basin or sink shall comply with the following requirements.
- 6.8.2 The contents of the closet or urinal shall not be discharged onto the road.
- 6.8.3 Except where the closet or urinal is designed to function as a sealed unit, the contents of the closet or urinal shall empty into a tank carried on the bus. Such tank shall be efficiently ventilated by means of a pipe the outlet of which is outside the passenger compartment.
- 6.8.4 Every tank into which the contents of a closet or urinal empties shall contain non-flammable and non-irritant chemicals of such character and in such quantity as to form at all times an efficient deodorant and germicide in respect of the contents of the tank; and
- 6.8.5 Hand basins or sinks shall not drain into any closet or urinal or into any tank into which a closet or urinal empties.

6.9. Passenger Stop Signal

- 6.9.1 A bus involved in frequent stops for the purpose of taking up or setting down passengers en route shall be provided with a passenger stop signal within convenient reach of each passenger to provide communication with the driver.

6.10. Sleeper Berth

- 6.10.1 Buses fitted with a sleeper berth shall comply with the Third Edition Australian Design Rule 42/-- *General Safety Requirement*, clause 17: Sleeper Berths (NB & NC Vehicles only)

7. SEATS

7.1. Driver's Seat

7.1.1 The driver's seat shall be so constructed that no person can occupy any portion of a seat on the right-hand side of the driver; soundly constructed and securely fastened to the structure; and designed and positioned in such a way that the driver can be comfortable and have proper control of the bus.

7.2. Seats for Passengers

7.2.1 The location of every passenger seating position shall be approved by the Minister and shall not be altered without an approval by the Central Inspection Authority.

7.2.2 Each seating position intended for adult use shall have: a dimension of not less than 400 mm when measured along the front of the seat cushion (Figure 7); a distance from the foremost point of each seat squab to the foremost point of the corresponding seat cushion of not less than 350 mm; and an average height of each undepressed seat cushion relative to the floor of not more than 500 mm and not less than 380 mm in the case of a *small bus*; or 400 mm in the case of a *large bus*.

7.2.3 Each seating position intended for use by *children* only shall have: a dimension of not less than 300 mm when measured along the front of the seat cushion (Figure 7); have a distance from the foremost point of each seat squab to the foremost point of the corresponding seat cushion of not less than 330 mm; and have a height of each undepressed seat cushion relative to the floor of not more than 430 mm and not less than 380 mm.

7.2.4 Three *children* may be seated on a seat designed to seat two adult passengers if the dimension across the front of the seat cushion is not less than 860 mm; any gap in the seat back is less than 100 mm; any gap in the seat cushion is less than 50 mm; and the seat back(s) remain upright when three *children* occupy the seat.

Note: Three children to a seat is a Gazette Notice and can be revoked at any time without notice.

7.2.5 There shall not be within the shaded area described in Figure 8 any obstruction horizontally forward of any point on the seat squab for a distance of 1,200 mm in the case of opposite facing seating positions; or 660 mm in the case of all other seating positions.

7.2.6 There shall not be between the floor, and the level of the seat cushion any obstruction in front of each seating position for a distance of 200 mm horizontally forwards of the seat cushion for a width of 150 mm each side of the centre of the passenger space. The spaces described in this clause shall not intersect each other or any other spaces designated for standing passengers or required minimum aisle width.

7.2.7 Where the normal floor level is interrupted by a wheel arch the height of each undepressed seat cushion relative to the floor shall not be less than 300 mm when measured from a point (B) 100 mm horizontally forward of the front edge of the seat cushion (Figure 9 left) providing that such point (B) on the wheel arch is not forward of the highest point (A) of the wheel arch. Should point (B) be forward of point (A) a level floor portion from point (B) forward (Figure 9 right) shall be provided in front of the seat to ensure that normal and reasonable foot space is available.

7.2.8 Each seat shall provide reasonable comfort and adequate support for passengers. The rear and top of the squab including any handrail shall be free of sharp edges and projections.

7.2.9 An ashtray shall not be fitted in the rear of a seat squab in such a manner that it may increase the risk of injury to a passenger.

7.2.10 Each seat shall be soundly constructed and securely fastened to the structure.

7.2.11 Fold down seats, commonly known as "flip" or "jump" seats shall not be accepted.

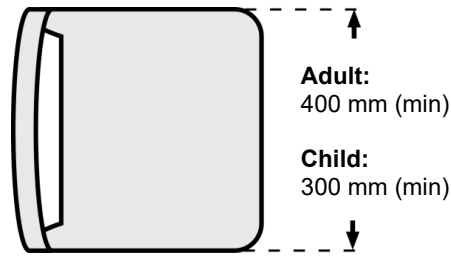

Figure 7: Top view of a seat

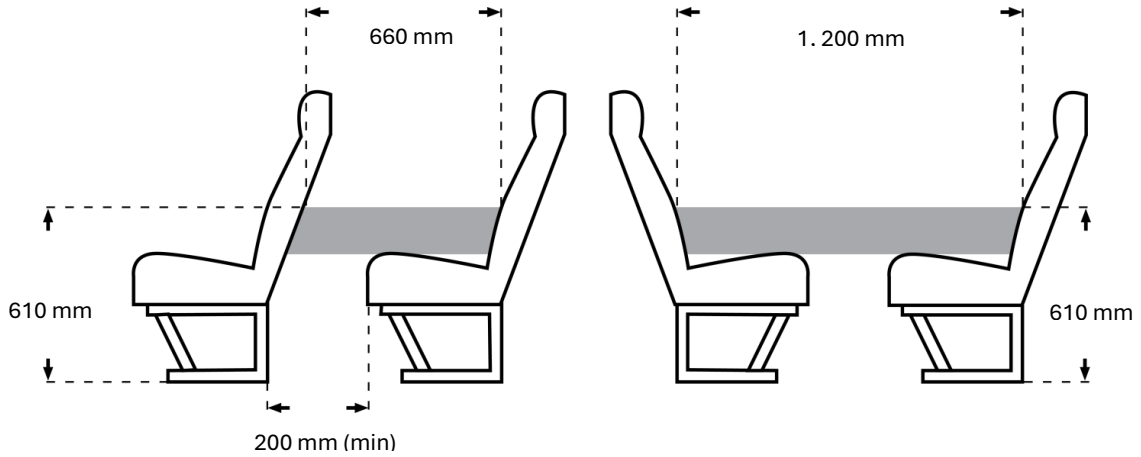

Figure 8: Side view of seating arrangement

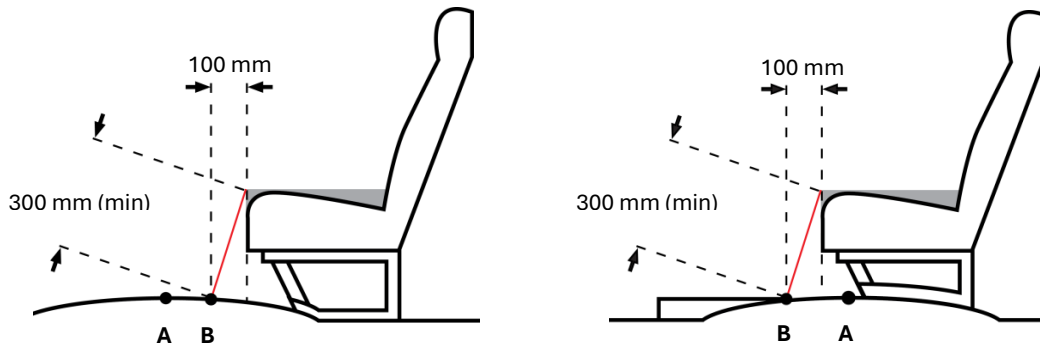

Figure 9: Side view of seats located near a wheel arch

7.3. Seat Belts

- 7.3.1 Seat belts, other than those required pursuant to Australian Design Rules, shall not be fitted without approval.
- 7.3.2 Where a seat is equipped with seatbelts the number of seating positions shall be the same as the number of seatbelt assemblies.
- 7.3.3 Every seat belt so fitted shall comply with one of the following requirements: AS 2596-2003 *Seat Belt Assemblies for Motor Vehicles*; or any other approved standard accepted as equivalent.

8. FIRE PROTECTION

8.1. General requirements

- 8.1.1 Flammable material, or material capable of being impregnated with fuel or lubricant, shall not be used in the engine compartment.
- 8.1.2 The engine compartment shall be designed to prevent accumulation of fuel and lubricating oil.
- 8.1.3 The engine compartment and other sources of heat shall be separated from the remainder of the bus by heat resistant material.
- 8.1.4 Unless effectively shielded, flammable material shall not be located within 100 mm of the exhaust system.
- 8.1.5 Flammable material shall be prevented from contacting any part of the exhaust or electrical system.

8.2. Fuel Systems

- 8.2.1 The fuel tank filler pipe shall not be located within any occupant or engine compartment.
- 8.2.2 The fuel tank filler inlet shall be so designed that any overflow or leakage cannot accumulate and shall be so located that it does not project beyond the overall width of the bodywork; is not less than 900 mm from either side of an access opening or emergency exit except in the case of a *small bus* having a seating capacity for not more than fifteen adults including the driver; is not located in the interior of the bus unless protected by a sealed cover plate; and is not located in any enclosed engine compartment.
- 8.2.3 No part of any fuel tank shall be less than 1,200 mm from the front of the bus; project beyond the overall width of the bodywork; be located in the interior of the bus or engine compartment; or be forward of the front axle in the case of a fuel tank storing petroleum.
- 8.2.4 Fuel systems shall be designed so that in the event of leaks the fuel flows freely to the road and is prevented from contacting the exhaust system or other sources of ignition.
- 8.2.5 The design of the fuel system shall not provide for gravity feed or self-sustaining feed to the carburettor or injectors.

8.3. Fire Extinguishers

- 8.3.1 There shall be provided on every bus in such a position as to be readily available for use a fire extinguisher which is selected and located in accordance with AS 2444-2001 *Portable fire extinguishers and fire blankets – Selection and location* as amended.

9. LIGHTING

9.1. Switching

9.1.1 Every switch needed to operate the lights required by the Road Traffic Act and Regulations for *light bus* or the Heavy Vehicle National Law and Regulation for a *heavy bus* shall be positioned to enable such switch to be operated by the driver when seated in the normal driving position.

9.2. Interior Lighting

9.2.1 The interior of a bus should be equipped with lights that will give sufficient light for the reasonable convenience of passengers.

9.2.2 Step treads and risers shall be adequately illuminated.

9.3. Reversing Lights

9.3.1 Where fitted reversing lights shall be at a height of not more than 2,000 mm above ground level.

9.4. Special Lighting for Articulated Buses

9.4.1 In addition to the lights required by the Road Traffic Act and Regulations for *light bus* or the Heavy Vehicle National Law and Regulation for a *heavy bus* shall an *articulated bus* shall be equipped with the following lights on each side.

9.4.2 A side marker lamp which displays red or yellow light to the rear and at 90 degrees to the side of bus at the rear of the front section.

9.4.3 A side marker lamp which displays yellow light to the front, and a yellow turn signal lamp at the front of the rear section.

9.4.4 The lights shall be located within 300 mm of the concertina section and be not less than 350 mm nor more than 1,500 mm above ground level measured from the centre of the light.

9.4.5 In addition to the lights required by this section there may be affixed adjacent to, or in conjunction with, side marker lights in the case of the light affixed to the rear of the front section a light displaying yellow light to the front; and in the case of the light affixed to the front of the rear section a light displaying red or yellow light to the rear and/or side of the bus.

9.4.6 Such lights shall be not less than 350 mm nor more than 1,500 mm above ground level measured from the centre of the light.

10. WHEELS AND TYRES

10.1. Condition and Fitting

10.1.1 A tyre shall not, if retreaded, be fitted to the foremost axle group.

10.1.2 No tyre, when operating at normal loading and inflation pressure, shall touch any other tyre or any part of the bus other than the rim to which it is attached nor with the wheels in the straight-ahead position protrude outside the body work of the bus.

10.2. Rims

- 10.2.1 Rims shall be free of any defects likely to render the bus unsafe.
- 10.2.2 No part of the rims or attachments to the rims shall project outside the bodywork of the bus or touch any part of the bus other than at the point of attachment.

11. GLAZING

11.1. Windscreens

- 11.1.1 All buses shall be equipped with a windscreen and any windscreen fitted to a bus shall be free of any cracks or chips likely to affect the driver's vision.

11.2. Windscreen Wipers and Washers

- 11.2.1 Where more than one wiper is fitted to a bus manufactured on or after 1 January 1978 all wipers should be operated by the one control and operate simultaneously.
- 11.2.2 Windscreen wipers shall be able to remove moisture from the part of the windscreen in front of the driver in the normal driving position to allow the driver an adequate view of the road ahead of the bus when the windscreen is wet; and able to be operated from the normal driving position.
- 11.2.3 All buses first registered on or after 1 January 1978 shall be fitted with a windscreen washer system with a water container of a minimum capacity of one litre, capable of directing water onto the exterior of the windscreen within each of the areas swept by the wiper or wipers so that when the wiper or wipers are operated they will disperse the water to the whole area swept by the wiper or wipers; and that the switch can be operated by the driver when seated in the normal driving position.

11.3. Demisters

- 11.3.1 To ensure that the driver obtains a full and uninterrupted view ahead while seated in the normal driving position all buses manufactured on or after 1 January 1978 shall be fitted with a device capable of removing condensed moisture from, and preventing the formation of moisture, on the inside of the windscreen.

11.4. Surface Film

- 11.4.1 Surface film having a maximum light reflectance value of 10 per cent may be applied to all windows of a bus rearward of the driver's seating position.
- 11.4.2 A minimum light transmittance value of 70 per cent may be applied to windows, excluding the windscreen, level and ahead of the driver.
- 11.4.3 Surface film having a maximum light reflectance value of 10 per cent and a minimum light transmittance value of 35 per cent may be applied to the windscreen of a bus above the level given by the highest point swept by the standard windscreen wiper or 10 per cent of the windscreen whichever is the higher.

Note: There is no mandated minimum light transmittance limits for windows rearward of the driver.

12. BRAKING

12.1. Operation

12.1.1 The application of the service brake shall be by means of a single control so placed that it can be actuated by the driver from the normal driving position.

12.2. Operation of Accessories

12.2.1 Accessories fitted to a bus shall not have their power supplied from the brake system main reservoir unless the reservoir is protected in the case of failure of the accessories.

13. EXHAUST

13.1. Exhaust System

13.1.1 A *light bus* shall be designed that the location of the exhaust outlet is rearward of the transverse centreline of the bus; discharges to the right or rear of the bus either horizontally or at not more than 45 degrees downwards; shall not extend beyond the perimeter of the bus when viewed in plan; and in the case of vertical exhaust systems be located behind the rearmost portion of the passenger compartment and shall discharge vertically upwards or rearwards at an angle above the horizontal.

14. OTHER EQUIPMENT

14.1. Steering

14.1.1 Buses shall have a right-hand drive. A right-hand drive bus means the centre of at least 1 steering control of the bus is to the right of the bus or in line with the centre of the bus.

14.2. Dangerous Fittings

14.2.1 A bus shall not be equipped with any object or fitting, not technically essential to such bus, which protrudes from any part of the bus so that it is likely to increase the risk of bodily injury to any person; or any object or fitting technically essential to such vehicle unless its design, construction and conditions and the manner in which it is affixed to the bus are such as to reduce to a minimum the risk of bodily injury to any person.

14.3. Bull Bars

14.3.1 A bus shall not be equipped with a bull bar that protrudes beyond the width of the front of the bus; has a pointed or sharp edge that is likely to cause injury to any person; detracts from the lighting and/or signalling system of the bus; or causes the bus to exceed the total length limit when the bus is equipped with additional components, e.g. bull bar and tow bar.

14.4. Mudguards

14.4.1 A bus shall be provided with wheel guards (parts of the bodywork, mudguards, etc) which shall be so designed as to protect other road users, as far as practicable, against thrown-up stones, mud, ice, snow and water and to reduce for those users the dangers due to contact with the moving wheels.

14.5. Tail Shaft Guards

14.5.1 In the case where the transmission incorporates any longitudinal drive shafts, couplings or intermediate shafts, provision shall be made to prevent the forward end of any such shaft or coupling contacting the road in the event of detachment of the forward end from its normal position.

14.6. Speedometer

14.6.1 Every bus shall be fitted with a speedometer which gives an indication of the speed of the bus on a single scale calibrated in kilometres per hour, displayed within the direct field of view of the driver and shall be clearly legible both day and night.

14.7. Visibility of Instruments and Warning Devices

14.7.1 Instruments and visible warning devices required by this Code of Practice, fitted to a bus first manufactured on or after 1 January 1978, shall be located forward of the driver and be in a location that is clearly visible to the driver when seated in the normal driving position.

15. MAINTENANCE PROCEDURES

15.1. Roadworthiness

15.1.1 Every bus shall be maintained in a safe and roadworthy condition at all times and the owner of the bus shall, for that bus, have carried out in accordance with Section 163GA of *the Act* the maintenance records as prescribed in Section 15.2 **Scheme of Maintenance** of *the Code*.

15.2. Scheme of Maintenance

15.2.1 The inspection and maintenance requirements detailed in this section are the minimum requirements to be carried out by the owner of the bus. These requirements are not intended to replace any higher level of regular servicing procedures determined by the owner or recommended by the manufacturer of the bus.

15.2.2 In addition to the prescribed inspection and maintenance requirements, the owner shall ensure that the person carrying out these requirements on the bus takes into account the inspection guidelines contained in the National Heavy Vehicle Inspection Manual (NHVIM) in respect to any fault which could cause the Central Inspection Authority to decline to issue a Certificate of Inspection in respect of the bus.

15.2.3 Satisfactory in the context of **MAINTENANCE PROCEDURES** means the inspection did not reveal any safety related faults which require rectification before the bus can be safely returned to service.

15.2.4 The prescribed forms upon which particulars of inspections and maintenance and repair work carried out on the bus are to be recorded in the English language shall be in the form of the Inspection Sheets and Maintenance Record numbered Part 1 to 4 in First Schedule of the Code of Practice for Buses.

15.2.5 The bus owner's (or company) name and address; the registration number of the bus; the odometer reading of the bus at the time of inspection; the date of the inspection; whether the inspection was satisfactory or not; and the name and signature of the person who carried out the inspection at the completion of the inspection shall be recorded in a copy of the Inspection Sheet.

15.2.6 The bus owner or company name and address; the registered number of the bus; the date and details of all maintenance and repair work carried out to the bus (brakes, suspension, steering, chassis, body structural members, or stub axles); and the odometer reading of the bus at the time the maintenance or repair is undertaken shall be recorded in a copy of the Maintenance Record.

15.2.7 Any item shown as not being satisfactory at the time of inspection shall be rectified before the bus is returned to service and the Inspection Sheet shall have recorded on it the date the item was rectified. This entry shall be signed by the person authorised by the owner of the bus to undertake the rectification work or by the person who undertook the initial inspection during which the item inspected was found not to be satisfactory.

15.2.8 If an item requiring rectification involves the brakes, suspension, steering, chassis, body structural members or stub axles of the bus the person undertaking the rectification work must ensure that the details are recorded by a person authorised by the owner to do so on a copy of the Maintenance Record.

15.3. Inspection Sheet No. 1

15.3.1 The owner of the bus shall cause the inspection detailed in this Section to be carried out at intervals not exceeding one month.

15.3.2 The inspections detailed in this clause shall be carried out by a person authorised by and known by the owner of the bus to be competent to undertake the inspection.

15.3.3 The signed form shall be retained by the owner and made available for inspection by officers of the Central Inspection Authority for a period of not less than six months after the date of inspection.

15.3.4 The inspection checks required to be carried out for the purpose of this clause are described on First Schedule of the Code of Practice for Buses Part 1 Inspection Sheet No. 1.

15.4. Inspection Sheet No. 2

15.4.1 The owner of the bus shall cause the inspection detailed in this Section to be carried out by a tradesman, motor mechanic, or a person authorised by the Central Inspection Authority, at intervals not exceeding three months or 15 000 kilometres of travel, whichever occurs first.

15.4.2 The signed form shall be retained by the owner and made available for inspection by officers of the Central Inspection Authority for a period of not less than twelve months after the date of inspection in the case of Inspection Sheet No. 2.

15.4.3 The inspection checks required to be carried out for the purpose of this clause are described on First Schedule of the Code of Practice for Buses Part 2 Inspection Sheet No. 2.

15.5. Inspection Sheet No. 3

15.5.1 The owner of the bus shall cause the inspection detailed in this Section to be carried out by a tradesman motor mechanic, or a person authorised by the Central Inspection Authority, at intervals not exceeding twelve months.

15.5.2 The signed form shall be retained by the owner and made available for inspection by officers of the Central Inspection Authority for a period of not less than three years after the date of inspection in the case of Inspection Sheet No. 3.

15.5.3 The inspection checks required to be carried out for the purpose of this clause are described on First Schedule of the Code of Practice for Buses Part 3 Inspection Sheet No. 3.

15.6. Maintenance Record

15.6.1 Each entry on the Maintenance Record shall be signed by a person authorised by the owner to do so.

15.6.2 The signed form shall be retained by the owner and made available for inspection by officers of the Central Inspection Authority for a period of not less than three years after the date of the last entry on the sheet in the case of the Maintenance Record.

16. INSPECTIONS

16.1. General

- 16.1.1 The Road Traffic Act and Regulations requires that every bus, unless exempted by the Minister, be inspected by the Central Inspection Authority at least once within each prescribed periodic interval.
- 16.1.2 The periodic interval is prescribed as a twelve-month period.
- 16.1.3 During the periodic interval the Central Inspection Authority may require a bus to be inspected at any time and place it deems fit.

16.2. Certificate of Inspections

- 16.2.1 Where a bus is inspected by the Central Inspection Authority and found to be satisfactory, a Certificate of Inspection will be issued for that bus.
- 16.2.2 The Certificate of Inspection may be subject to such conditions as the Central Authority thinks fit.

16.3. Inspection Guidelines

- 16.3.1 The National Heavy Vehicle Inspection Manual (NHVIM) applies to all buses, including *light buses*, for the inspection purposes.
- 16.3.2 Requirements stated in the sub-section 13.4 of the NHVIM do not apply for the inspection of the buses manufactured prior to 1 July 1988 in South Australia.
- 16.3.3 The requirements of *the Code* shall be applied for the inspection of the buses manufactured prior to 1 July 1988, instead of sub-section 13.4 of the NHVIM.
- 16.3.4 The Central Inspection Authority may also conduct, or request, other inspection procedures it deems necessary to ensure that buses meet all requirements of *the Code* and are in a safe and roadworthy condition.

APPENDIX

A Related Third Edition ADRs

The Code		ADRs
3.2	Ground Clearance	ADR 43/--
3.4	Ability to reverse	ADR 42/--
5.1	Access Steps	ADR 58/--
5.2	Access Doors	ADR 58/--
5.3	Aisles	ADR 58/--
5.4	Head Room	ADR 58/--
5.5	Emergency Exits	ADR 44/-- ADR 58/--
6.1	Interior Appointments	ADR 58/--
6.2	Hand Straps and Rails	ADR 58/--
6.3	Internal Guard Rails and Partitions	ADR 58/--
6.5	Floors	ADR 58/--
6.6	Interior Doors	ADR 58/--
6.7	Ventilation	ADR 42/--
6.8	Lavatories and Wash Basins	ADR 42/--
6.9	Passenger Stop Signal	ADR 58/--
6.10	Sleeper Berth	ADR 42/--
7.1	Driver's Seat	ADR 58/--
7.2	Seats for Passengers	ADR 58/--
7.3	Seat Belts	ADR 04/--
8.1	General Requirements	ADR 58/--
8.2	Fuel System	ADR 58/--
8.3	Fire Extinguishers	ADR 58/--
9.2	Interior Lighting	ADR 58/--
11.2	Windscreen Wipers and Washers	ADR 42/--
11.3	Demisters	ADR 42/--
11.4	Surface Film	ADR 08/--
12.1	Brake Operation	ADR 35/--
14.2	Dangerous Fittings	ADR 42/--
14.3	Bull Bars	ADR 43/--
14.4	Mudguards	ADR 42/--
14.5	Tail Shaft Guards	ADR 58/--
14.6	Speedometer	ADR 18/--
14.7	Visibility of Instruments and Warning Devices	ADR 18/--

FIRST SCHEDULE: PART 1



Government of South Australia

Department for Infrastructure
and Transport

**Code of Practice for Buses
Mandatory Maintenance Procedure
Part 1**

**Vehicle Inspections
PO BOX 1533
ADELAIDE SA 5001**

**MR 1090
07/16**

Company / Owner **Registration Number**

Address

Date **Odometer** **km**

INSPECTION SHEET NUMBER 1

To be undertaken at interval of not more than one month.

- All inspection procedures to be carried out in accordance with the appropriate requirements of the CODE OF PRACTICE FOR BUSES

Item	Satisfactory		Rectified	
	Yes (✓)	No (X)	Date	Signed
TYRES & WHEELS				
Wheel Nuts for Tightness				
Wheels for Condition				
Tyres for Correct Pressure				
Tyre Tread for Condition & Depth				
Tyre Walls (without wheel removal) for Damage				
Tyre Construction for Correct Location				
BRAKES				
Service & Parking Brake for Correct Operation				
Brake System for Air Leaks				
Drain Valves for Operation				
Hydraulic Fluid for Level & Leaks				
Brake Warning System for Operation				
ABS & EBS Warning System for Operation				
BATTERY				
Battery Terminals & Cables for Condition				
Battery & Battery Carrier Security				
GENERAL				
Power Steering System Leaks				
Engine for Oil & Water Leaks				
Exhaust System for Condition, Security & Efficiency				
Gearbox & Differential Oil Leaks				
Fuel System Leaks				
BODY				
Glazing Condition				
Body Exterior for Damage & Dangerous Projections				
Engine Cover Sealing Inside Passenger Compartment for Condition				
Rear Vision Mirrors for Security & Condition				
Passenger Access Doors for Security & Operation				
Seats for Security				
Steps, Floor & Hatches for Security & Condition				
Fire Extinguisher for Presence & in Service Date				
LIGHTING				
Headlamps, Park, Rear, Clearance, No. Plate, Stop, Reverse Lights & Turn Signal for Operation & Damaged Lenses				
Dash Lights, Step, Interior & Destination Lights for Operation				
CONTROLS				
Neutral Safety Switch for Operation (Automatic Vehicles Only)				
Gear & Clutch Controls for Correct Operation				
Steering System for Free Play & Slackness				
Windscreen Wipers for Operation & Condition				
Windscreen Washers for Operation				
Demister for Operation				
Horn for Operation				

Inspection Undertaken by Signed..... Date .../.../.....

*This form must be kept for a period of at least six (6) months after the inspection.

FIRST SCHEDULE: PART 2



Government of South Australia
Department for Infrastructure
and Transport

**Code of Practice for Buses
Mandatory Maintenance
Procedure Part 2**

**Vehicle Inspections
PO BOX 1533
ADELAIDE SA 5001**

**MR 1090
07/16**

Company / Owner **Registration Number**

Address

Date **Odometer** km

INSPECTION SHEET NUMBER 2

To be undertaken at intervals of not more than three months or 15,000 km whichever occurs first

- All inspection procedures to be carried out in accordance with the appropriate requirements of the CODE OF PRACTICE FOR BUSES

Item	Satisfactory		Rectified		
	Yes (✓)	No (X)	Date	Signed	
SUSPENSION					
"U" Bolts & Centre Bolts for Security & Condition					
Radius Rods & Joints for Condition					
Front & Rear Axle Mounts for Condition & Cracks					
Springs & Shackles for Condition					
Shock Absorber & Joints for Condition					
Air Bag System for Condition					
BRAKES					
Brake Lines & Mounts for Condition					
Slack Adjusters & Auto Adjusters for Operation & Condition					
Brake Linings for Wear & Contamination					
Air Filter for Security & Cleanliness					
Air Priority System for Operation					
Air or Vacuum for Correct Build Up Time					
Retarder & Exhaust Brake for Operation & Control					
STEERING					
Steering Box for Security & Operation					
Steering System for Condition & Play					
Steering Wheel & Column for Play & Security					
GENERAL					
Engine Insulating Material for Contamination & Security					
Starter Motor for Security					
Tail Shafts & Guards for Condition & Security					
Universal Joints & Splines for Condition					
Fuel Tank & Fuel System for Security					
Wheel Bearings for Adjustment					
Axle Hub Seals for Leaks					
Seat Belt Condition & Operation					
Door Interlocks for Correct Operation (if fitted)					
BODY					
Body Mounts Attachments for Security & Condition					
Body for Visual Structural Defects & Corrosion					

Inspection Undertaken by Signed..... Date / /

*This form must be kept for a period of at least one (1) year after the inspection.

