



Transport SA

ABN 41 659 119 911

MR23

NOTIFICATION OF A WRITTEN-OFF VEHICLE

WRI

May be lodged at any TRANSPORT SA or SERVICE SA Customer Service Centre. Telephone Enquiries: 13 10 84

05/04

- Carefully read all the information on both sides before completing this application. Please write clearly in BLOCK LETTERS. This notification will not cancel the registration of the vehicle. An 'Application to Cancel Registration' is required. If you have any questions, ask a Transport SA or Service SA Customer Service officer for assistance.

1. DETAILS OF THE VEHICLE

Form with fields for VEHICLE IDENTIFICATION NUMBER (VIN), PLATE NUMBER, STATE REGISTERED, MAKE, MODEL, TYPE OF VEHICLE, ENGINE NUMBER, ODOMETER READING.

2. ABOUT THE PERSON OR BUSINESS ADVISING THE NOTIFICATION

Form with fields for SURNAME/BODY CORPORATE NAME, GIVEN NAMES, CLIENT NUMBER, POSTAL ADDRESS, SUBURB/TOWN, POSTCODE, CONTACT TELEPHONE NUMBER.

3. AUTHORITY OF PERSON & CATEGORY OF WRITE-OFF

Form with questions about when the vehicle was declared written-off, authority for advising the write-off, and category of write-off (Private Owner, Wrecker/Dismantler, Auction House, Insurance Company, Other).

4. DAMAGE DETAILS

Before completing the details below please refer to the information on the reverse side

- Complete the relevant table/s below by: (A) Placing a Damage Incident Type code (as indicated below) in the Damage Incident Type box, and (B) Recording the Severity of Damage by placing a Severity of Damage Code (as shown on the reverse side) in the box/es next to the locations of damage.

Table with columns for Damage Incident Type and Severity of Damage for Motor Vehicle, Motor Bike, and Trailer/Caravan. Includes an example of how to complete the tables.

5. SIGNATURE

I declare that the information provided on this form is true and correct. Signature.....Date...../...../.....

Notice Serial No. [] Approval No. [] Statutory Write-off warning notice issued? Yes [] No [] Plates surrendered with this application? Yes [] No []

NOTIFICATION OF A "WRITTEN-OFF" VEHICLE

The Registrar of Motor Vehicles must be advised of the following written-off vehicles if the vehicle is less than 15 years of age:

- motor vehicles (other than a motor bike or trailer) with a GVM not greater than 4.5 tonnes;
- motor bikes and caravans;
- trailers with a GVM greater than 4.5 tonnes.

- If you are the private owner of a vehicle that has been written-off, you must notify the Registrar before selling or otherwise disposing of the vehicle.
- If you are a motor vehicle dealer, auction house or vehicle wrecker/dismantler you must advise the Registrar within 7 days of acquiring or declaring a vehicle to be a written-off vehicle, or if you are an insurer, within 7 days of declaring a vehicle to be a written-off vehicle.
- For a motor vehicle dealer, auction house, vehicle wrecker/dismantler or insurer, 'Written-Off Vehicle Notice/s' must be affixed to the vehicle as soon as practicable and prior to it or any parts being sold or otherwise disposed of.

WHAT IS A "WRITTEN-OFF" VEHICLE

A vehicle is written-off if it is a total loss, or is to be, or has been, wrecked or wholly or partly disassembled for salvage, or is to be, or has been, sold or acquired for wrecking or disassembling for salvage.

WHAT IS A STATUTORY "WRITE-OFF"

'Statutory write-off' means a motor vehicle or trailer that is written-off and is:

- a motor vehicle (other than a motor bike or a trailer) that has been:
 - immersed in salt water above the door sill level for any period; or
 - immersed in fresh water up to the dashboard or steering wheel for more than 48 hours; or
- a motor bike that has been:
 - fully immersed in salt water for any period; or
 - fully immersed in fresh water for more than 48 hours; or
- a motor vehicle or trailer that is burnt to such an extent that it is fit for only wrecking or scrap; or
- a motor vehicle that is stripped of all, or a combination of most, interior and exterior body parts, panels, and components (such as, for example, the engine, wheels, bonnet, guards, door, boot lid); or
- a motor vehicle (other than a motor bike or trailer) that is damaged by at least three of the following impact damage indicators:
 - damage to an area of the roof equal to or exceeding 300 mm by 300 mm in size;
 - damage to an area of the cabin floor pan equal to or exceeding 300 mm by 300 mm in size;
 - damage to an area of the firewall equal to or exceeding 300 mm by 300 mm in size;
 - any damage to the suspension;
 - damage to major mechanical component such as the engine block or transmission casings (for example, where the component is cracked or broken); or
- a motor bike that has impact damage (excluding scratching) to the suspension and at least two areas of structural frame damage.

A Repairable write-off is a written-off vehicle that is not a Statutory write-off.

DAMAGE INCIDENT TYPES

- (I) Impact** - Collision of some type with an object, for example another vehicle, tree or pole.
- (F) Fire** - Damage caused by combustion.
- (M) Malicious / Stripping** - Intentional damage, for example broken door locks, glass window or windows, paint scratched or stripped of all or a combination of interior and exterior body parts.
- (W) Water** - Damage caused by water (salt or freshwater) such as a storm, river or flood.
- (H) Hail** - Damaged caused by hail stones.

LOCATION OF DAMAGE

Passenger/Light Commercial

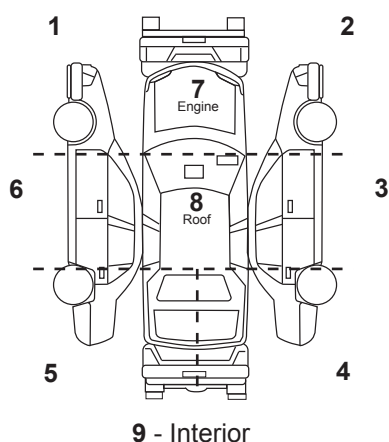

Trailer/Caravan

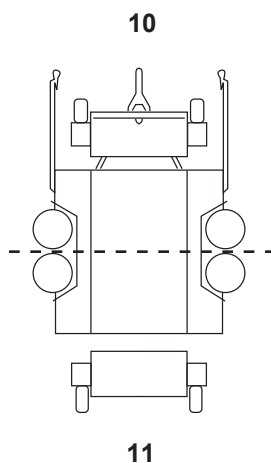

Motorcycle

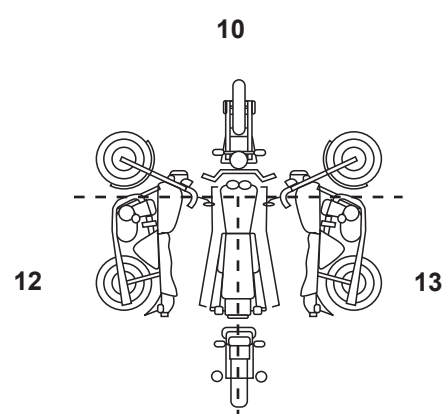

14 - Whole vehicle (applies to all vehicle types)

SEVERITY CODES

- A - Heavy Panel (replace panel)
- B - Light Panel (repairable)
- C - Heavy Structural
- D - Light Structural
- E - Unrepairable (physical or economic)
- F - Major Engine Damage
- G - Minor Engine Damage
- H - Major Stripping (interior parts, external panels)
- I - Minor Stripping (wheels, radio, damaged locks)
- J - Major Vandalism (interior parts, external panels)
- K - Minor Vandalism (wheels, radio, damaged locks)
- L - Full Salt Water Immersion
- M - Full Fresh Water Immersion
- N - Burnt (more than one third of vehicle completely burnt or burnt to the extent that repairs are not economic)
- O - Smoke and Heat (minor engine fire or minor interior exposed to external heat source)
- P - Minor Smoke (smoke and / or soot damage to the interior)

PENALTIES APPLY FOR FAILURE TO NOTIFY THE REGISTRAR WITHIN THE PRESCRIBED PERIOD AND FOR NOT AFFIXING WRITTEN-OFF VEHICLE NOTICE/S